

ROTARY VANE COMPRESSORS



- Dry running vane pump
- Compact & lightweight
- Low noise
- Dual 110Vac and 230Vac power supply
- Air flow to suit 1 or 2 T2C torches

These small, dry running, rotary vane compressors are suitable for operating Goodburn T2C plastic welding torches. They are compact with very low noise levels and are easy to build into other equipment.

The pumps are available in two capacities - 110 litres per minute (0523) and 220 litres per minute (1023) free air flow. These capacities are suitable for operating 1 and 2 T2C torches respectively. Both models have dual 100-120Vac and 220-240Vac, 50/60Hz power supplies.

All models are supplied with an inlet silencer, pressure relief valve and outlet hose connection as standard. All the air handled is filtered by a built in micro line filter.

SPECIFICATION

Power supply : 110 -120 and 220 - 240Vac
50/60Hz

Power drain : 0523 : 190W
1023 : 560W

Capacity : 0523 : 110 litres/minute
1023 : 220 litres/minute
(with open air flow)

Motor speed : 1425rpm

Weight : 0523 : 14.4Kg
1023 : 21.2Kg

DIMENSIONS

MODEL 0523

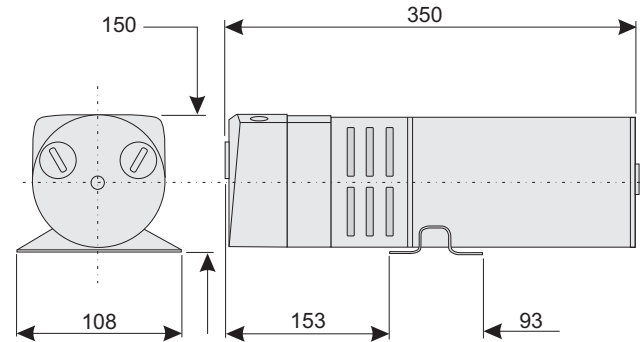

MOUNTING DETAIL

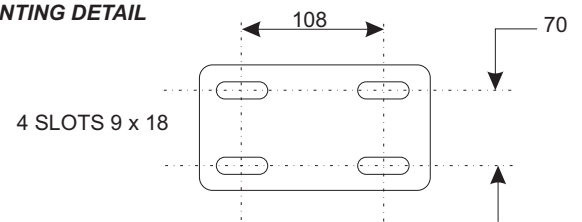

MODEL 1023

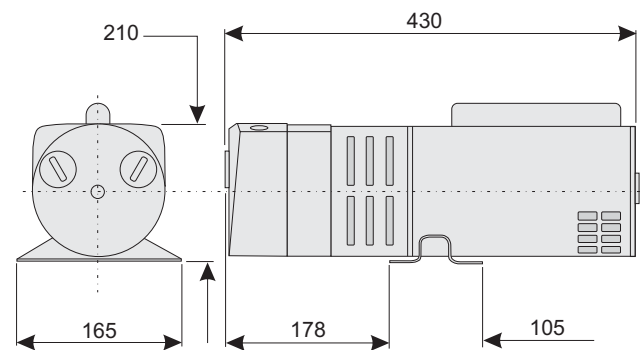

MOUNTING DETAIL

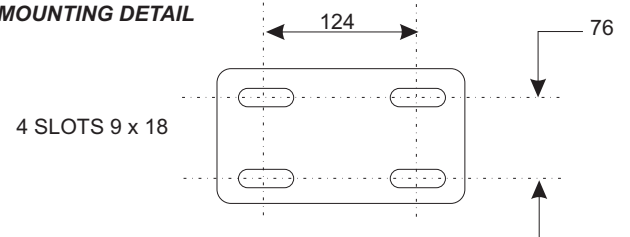

STANDARD ITEMS

Voltage	Flow rate	Part Number
100-240 Vac	110 l/min	0523
100-240 Vac	220 l/min	1023